

SAE "C" 2-4 HOLES

S8

Conforms to SAE J744

D010-D10/0505

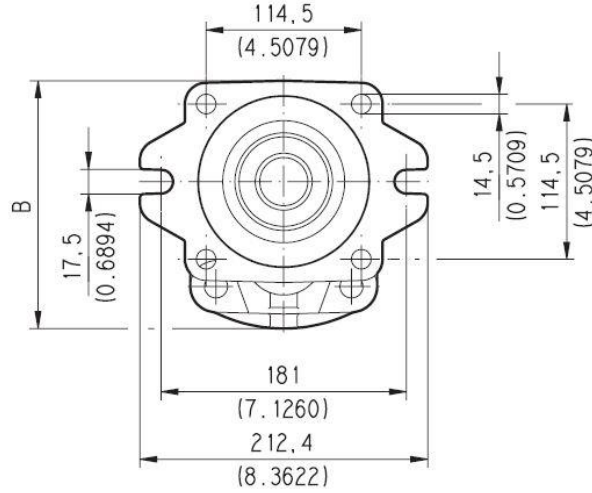
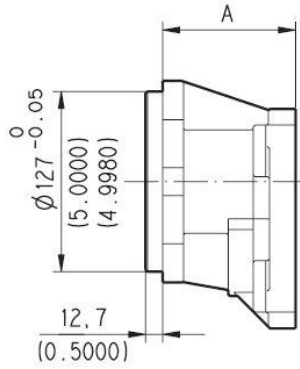

SAE "C" SPLINE

06

Mounting face refer to flange code **S8**

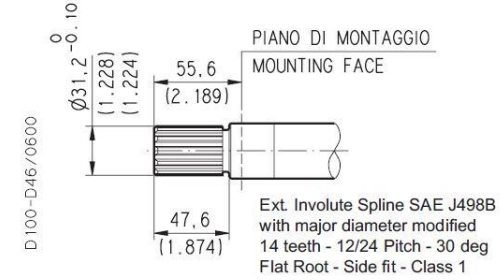

HD. 30 MAX 170 Nm (1505 lbf in) ♦

HD. 35 MAX 900 Nm (7966 lbf in) ♦

Pump type HDP Motor type HDM	Displacement in ³ /rev (cm ³ /rev)	Max. pressure			Max. speed	Min. speed
		p ₁	p ₂	p ₃		
		psi (bar)			min ⁻¹	
HD. 30•17	1.05 (17,28)	4060 (280)	4350 (300)	4640 (320)	3000	400
HD. 30•22	1.34 (21,99)	4060 (280)	4350 (300)	4640 (320)	3000	400
HD. 30•24	1.47 (24,03)	4060 (280)	4350 (300)	4640 (320)	3000	400
HD. 30•27	1.63 (26,70)	4060 (280)	4350 (300)	4640 (320)	3000	400
HD. 30•34	2.11 (34,56)	3915 (270)	4205 (290)	4495 (310)	3000	400
HD. 30•38	2.40 (39,27)	3915 (270)	4205 (290)	4495 (310)	3000	400
HD. 30•43	2.68 (43,98)	3770 (260)	4060 (280)	4350 (300)	3000	400
HD. 30•51	3.16 (51,83)	3335 (230)	3770 (260)	4060 (280)	2500	300
HD. 30•56	3.45 (56,55)	3118 (215)	3553 (245)	3843 (265)	2500	300
HD. 30•61	3.74 (61,26)	2900 (200)	3335 (230)	3625 (250)	2000	250
HD. 30•73	4.50 (73,82)	2755 (190)	3045 (210)	3335 (230)	1700	250
HD. 30•82	4.98 (81,68)	2465 (170)	2755 (190)	3045 (210)	1500	250

SAE FLANGED PORTS J518 - Standard pressure series 3000 PSI

SSM

Metric thread ISO 60° conforms to ISO/R 262

CODE	A	B	C	D		
	mm (in)	mm (in)	mm (in)	Thread Depth mm (in)	Nm (lbf in)	Nm (lbf in)
MB	19 (0.7480)	47,6 (1.8740)	22,2 (0.8740)	M 10 22 (0.8661)	20 ⁺¹ (177 + 186)	35 ^{+2,5} (310 + 332)
MC	24,5 (0.9646)	52,4 (2.0630)	26,2 (1.0315)	M 10 22 (0.8661)	20 ⁺¹ (177 + 186)	35 ^{+2,5} (310 + 332)
MD	30,5 (1.2008)	58,7 (2.3110)	30,2 (1.1890)	M 10 22 (0.8661)	20 ⁺¹ (177 + 186)	35 ^{+2,5} (310 + 332)
ME	39,3 (1.5472)	69,8 (2.7480)	35,7 (1.4055)	M 12 27 (1.0630)	30 ^{+2,5} (266 + 288)	65 ⁺⁵ (575 + 620)
MF	51 (2.0079)	77,8 (3.0630)	42,9 (1.6890)	M 12 27 (1.0630)	30 ^{+2,5} (266 + 288)	—

D010-D15/0405

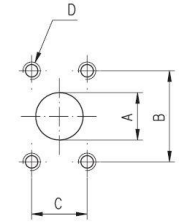

SAE FLANGED PORTS J518 - Standard pressure series 3000 PSI

SSS

American straight thread UNC-UNF 60° conforms to ANSI B 1.1

CODE	A	B	C	D		
	mm (in)	mm (in)	mm (in)	Thread Depth mm (in)	Nm (lbf in)	Nm (lbf in)
SB	19 (0.7480)	47,6 (1.8740)	22,2 (0.8740)	3/8 - 16 UNC-2B 22 (0.8661)	20 ⁺¹ (177 + 186)	30 ^{+2,5} (266 + 288)
SC	24,5 (0.9646)	52,4 (2.0630)	26,2 (1.0315)	3/8 - 16 UNC-2B 22 (0.8661)	20 ⁺¹ (177 + 186)	30 ^{+2,5} (266 + 288)
SD	30,5 (1.2008)	58,7 (2.3110)	30,2 (1.1890)	7/16 - 14 UNC-2B 28,5 (1.1220) 7/16 - 14 UNC-2B 27 (1.0630) (♦)	25 ⁺¹ (221 + 230)	55 ⁺⁵ (487 + 531)
SE	39,3 (1.5472)	69,8 (2.7480)	35,7 (1.4055)	1/2 - 13 UNC-2B 27 (1.0630)	30 ^{+2,5} (266 + 288)	70 ⁺⁵ (620 + 664)
SF	51 (2.0079)	77,8 (3.0630)	42,9 (1.6890)	1/2 - 13 UNC-2B 27 (1.0630)	30 ^{+2,5} (266 + 288)	—

D010-D15/0405

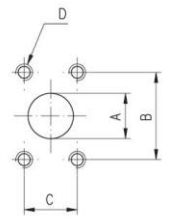

(♦) For MAGNUM 35