

BGM



MOTORI ORBITALI

HYDRAULIC MOTORS SERIES

CARATTERISTICHE DEL MOTORE MOTOR FEATURES

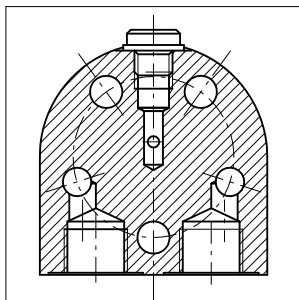

Alimentazione laterale.
Side ports configuration.

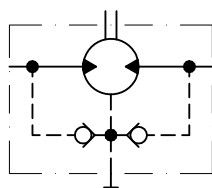

Possibilità di alimentazione laterale o posteriore.
Rear and side ports option.

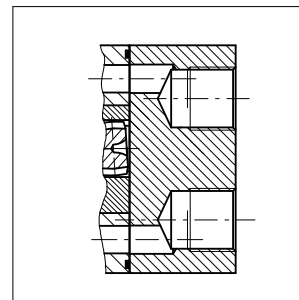

Alimentazione posteriore.
Rear ports configuration.

Buone capacità di carico radiale e assiale.
Very good side and axial load capacity.

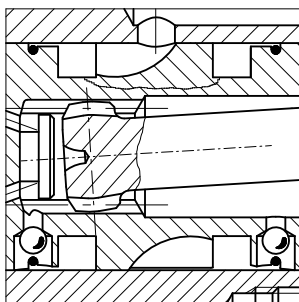

Distribuzione radiale e tolleranze ridotte al minimo per assicurare un drenaggio ridotto - Valvole interne di drenaggio.
Optimized spool valve design to minimize the leakage - built-in check valves.

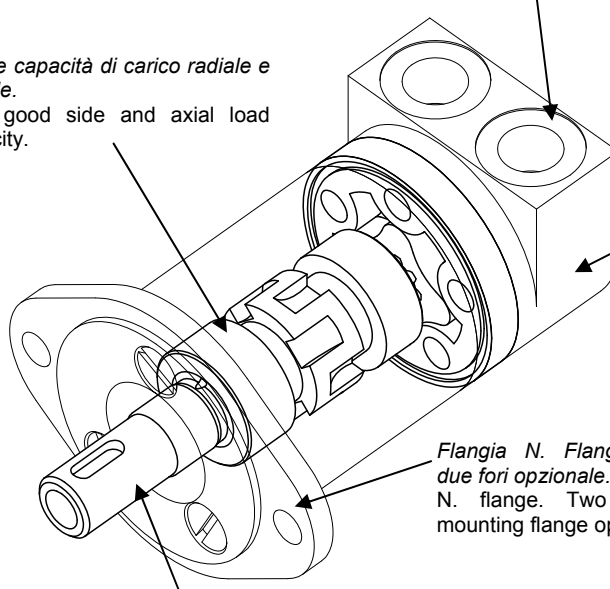

Valvole interne di drenaggio.
Built - in check valves.

Flangia N. Flangia a due fori opzionale.
N. flange. Two bolt mounting flange option.

Elevato rapporto coppia/peso e buona regolarità a basso numero di giri.
High torque/weight ratio and very good low speed performance.

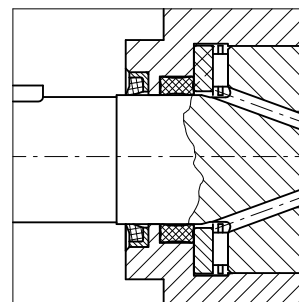

Parapolvere per proteggere la guarnizione di tenuta dell'albero dalle impurità.
Dust seal to protect the high pressure shaft seal.

CARATTERISTICHE TECNICHE TECHNICAL SPECIFICATIONS

Motore Motor	Cilindrata Displacement cm ³ /giro [in ³ /rev]	Max. pressione in ingresso Max. input pressure bar [psi]		Pressione diff. max. Max. differential pressure bar [psi]		Coppia max.* Max. torque* Nm [lbf-ft]		Portata max. Max. flow l/min [U.S. gpm]		Velocità max. Max. speed rpm		Potenza max. Max. horsepower kW [hp]	
		Cont Int ¹⁾ Peak ²⁾	140 [2030] 175 [2537] 225 [3265]	Cont Int ¹⁾ Peak ²⁾	100 [1450] 140 [2030] 200 [2900]	Cont Int ¹⁾ Peak ²⁾	16 [11.7] 23 [16.9] 33 [24.3]	Cont Int ¹⁾	20 [5.28] 25 [6.60]	Cont Int ¹⁾	1550 1935	Cont Int ¹⁾	2.3 [3.08] 3.2 [4.28]
BGM 013	12.9 [0.78]	Cont Int ¹⁾ Peak ²⁾	140 [2030] 175 [2537] 225 [3265]	Cont Int ¹⁾ Peak ²⁾	100 [1450] 140 [2030] 200 [2900]	Cont Int ¹⁾ Peak ²⁾	16 [11.7] 23 [16.9] 33 [24.3]	Cont Int ¹⁾	20 [5.28] 25 [6.60]	Cont Int ¹⁾	1550 1935	Cont Int ¹⁾	2.3 [3.08] 3.2 [4.28]
BGM 020	20 [1.22]	Cont Int ¹⁾ Peak ²⁾	140 [2030] 175 [2537] 225 [3265]	Cont Int ¹⁾ Peak ²⁾	100 [1450] 140 [2030] 200 [2900]	Cont Int ¹⁾ Peak ²⁾	25 [18.4] 35 [25.7] 51 [37.5]	Cont Int ¹⁾	20 [5.28] 25 [6.60]	Cont Int ¹⁾	1000 1250	Cont Int ¹⁾	2.3 [3.08] 3.3 [4.42]
BGM 032	31.8 [1.93]	Cont Int ¹⁾ Peak ²⁾	140 [2030] 175 [2537] 225 [3265]	Cont Int ¹⁾ Peak ²⁾	100 [1450] 140 [2030] 160 [2320]	Cont Int ¹⁾ Peak ²⁾	39 [28.7] 54 [39.7] 60 [44.2]	Cont Int ¹⁾	20 [5.28] 25 [6.60]	Cont Int ¹⁾	625 785	Cont Int ¹⁾	2.3 [3.08] 2.8 [3.75]
BGM 040	40.1 [2.44]	Cont Int ¹⁾ Peak ²⁾	140 [2030] 175 [2537] 225 [3265]	Cont Int ¹⁾ Peak ²⁾	100 [1450] 140 [2030] 160 [2320]	Cont Int ¹⁾ Peak ²⁾	50 [36.8] 67 [49.3] 76 [56.0]	Cont Int ¹⁾	20 [5.28] 25 [6.60]	Cont Int ¹⁾	495 620	Cont Int ¹⁾	1.8 [2.41] 2.5 [3.35]
BGM 050	50 [3.05]	Cont Int ¹⁾ Peak ²⁾	140 [2030] 175 [2537] 225 [3265]	Cont Int ¹⁾ Peak ²⁾	80 [1160] 140 [2030] 160 [2320]	Cont Int ¹⁾ Peak ²⁾	49 [36.1] 83 [61.1] 94 [69.2]	Cont Int ¹⁾	20 [5.28] 25 [6.60]	Cont Int ¹⁾	400 500	Cont Int ¹⁾	1.8 [2.41] 2.4 [3.21]

¹⁾ Le condizioni intermittenti non devono durare più del 10% di ogni minuto / Intermittent duty must not exceed 10% each minute.

²⁾ Le condizioni di picco non devono durare più del 1% di ogni minuto / Peak duty must not exceed 1% each minute.

Motore Motor	Pressione max scar. con drenaggio Max return pressure with drain line bar [psi]		Pressione max avviamento a vuoto Max starting pressure with no load bar [psi]		Coppia minima di spunto Min starting torque Nm [lbf-ft]	
	Cont Int ¹⁾ Peak ²⁾	140 [2030] 175 [2537] 225 [3265]	Cont Int ¹⁾ Peak ²⁾	80 [1160] 140 [2030] 160 [2320]	A press. diff. Max At max Δp	Cont Int ¹⁾
BGM 013	Cont Int ¹⁾ Peak ²⁾	140 [2030] 175 [2537] 225 [3265]	Cont Int ¹⁾ Peak ²⁾	80 [1160] 140 [2030] 160 [2320]	A press. diff. Max At max Δp	Cont Int ¹⁾
BGM 020	Cont Int ¹⁾ Peak ²⁾	140 [2030] 175 [2537] 225 [3265]	Cont Int ¹⁾ Peak ²⁾	80 [1160] 140 [2030] 160 [2320]	A press. diff. Max At max Δp	Cont Int ¹⁾
BGM 032	Cont Int ¹⁾ Peak ²⁾	140 [2030] 175 [2537] 225 [3265]	Cont Int ¹⁾ Peak ²⁾	80 [1160] 140 [2030] 160 [2320]	A press. diff. Max At max Δp	Cont Int ¹⁾
BGM 040	Cont Int ¹⁾ Peak ²⁾	140 [2030] 175 [2537] 225 [3265]	Cont Int ¹⁾ Peak ²⁾	80 [1160] 140 [2030] 160 [2320]	A press. diff. Max At max Δp	Cont Int ¹⁾
BGM 050	Cont Int ¹⁾ Peak ²⁾	140 [2030] 175 [2537] 225 [3265]	Cont Int ¹⁾ Peak ²⁾	80 [1160] 140 [2030] 160 [2320]	A press. diff. Max At max Δp	Cont Int ¹⁾

MASSIMA PRESSIONE AMMESSA SULLA GUARNIZIONE ALBERO MAX PERMISSIBLE SHAFT SEAL PRESSURE

Pressione massima di scarico senza drenaggio o massima pressione nella linea di drenaggio.

Max. return pressure without drain line or max. pressure in the drain line.

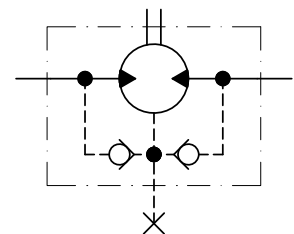
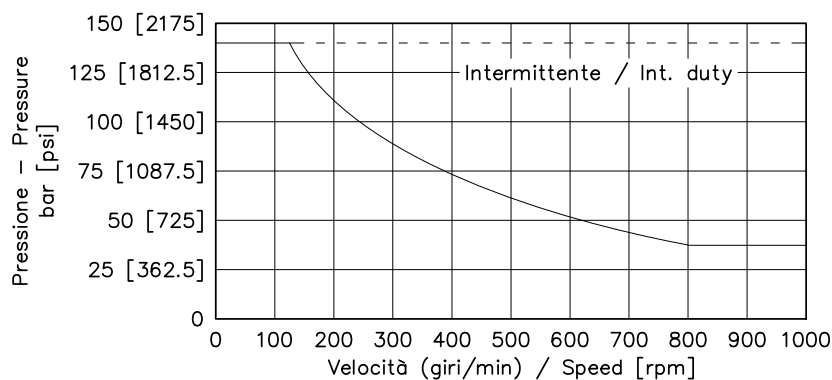

PERDITE DI CARICO PER ATTRAVERSAMENTO PRESSURE LOSS

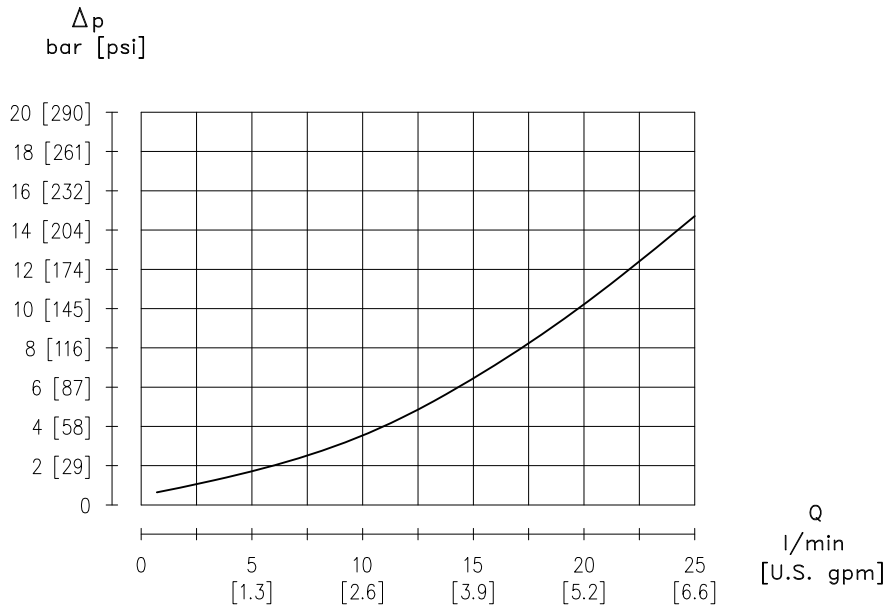

Il diagramma è stato ottenuto con prove eseguite su un numero significativo di motori, utilizzando un'olio avente una viscosità cinematica di 37 cSt alla temperatura di 45° C.

Diagram according to tests done with a relevant number of motors and using hydraulic oil with kinematic viscosity of 37 cSt at 45° C temperature.

CODICE DI ORDINAZIONE ORDERING CODE

Le seguenti lettere o numeri del codice, sono state sviluppate per identificare tutte le configurazioni possibili dei motori BGM. Usare il seguente modulo per identificare le caratteristiche desiderate. **Tutte le lettere o numeri del codice devono comparire in fase d'ordine.** Si consiglia di leggere attentamente il catalogo prima di iniziare la compilazione del codice di ordinazione.

The following alphanumeric digits system has been developed to identify all of the configuration options for the BGM motors. Use the model code below to specify the desired features. **All alphanumeric digits system of the code must be present when ordering.** We recommend to carefully read the catalogue before filling the ordering code.

CODICE PRODOTTO / MODEL CODE

1	2	3	4	5	6	7	8	8A	9	10

1 - SERIE / SERIES

BGM	Motore orbitale Orbital motor
-----	----------------------------------

2 - FLANGIA / FLANGE

S	3 fori M6 - Ø31.5mm 3 bolts M6 - Ø31.5mm [Ø 1.2 in]	STANDARD
N	2 fori - Ø63mm 2 bolts - Ø63mm [Ø 2.4 in]	

3 - CILINDRATA / DISPLACEMENT

013	12.9 cm ³ /giro [0.78 in ³ /rev]
020	20 cm ³ /giro [1.22 in ³ /rev]
032	31.8 cm ³ /giro [1.93 in ³ /rev]
040	40.1 cm ³ /giro [2.44 in ³ /rev]
050	50 cm ³ /giro [3.05 in ³ /rev]

4 - COPERCHIO / COVER

FR0	Versione Base Standard Version
SP1	Versione SP1 SP1 Version
FRQ	Versione Q Q Version

5 - ATTACCHI / MAIN PORTS

		COPERCHIO / COVER		
		FR0	SP1	FRQ
M06	Attacchi 3/8 G (BSPP) 3/8 G (BSPP) Main Ports	STANDARD	•	•
S06	Attacchi 9/16 - 18 UNF 9/16 - 18 UNF Main Ports		•	/

• Disponibile - Available / Non Disponibile - Not Available

6 - ESTREMITÀ ALBERO / SHAFT END

CL160	Cilindrico Ø16 mm Parallel keyed Ø16 mm [0.6 in]
SC160	Scanalato profilo B17x14 DIN5482 B17x14 DIN5482 Splined

7 - TENUTE / SEALS

N	NBR
---	-----

1	2	3	4	5	6	7	8	8A	9	10

8 - VALVOLE / VALVES

		ATTACCHI / MAIN PORTS	
		M06	S06
XXXX	Non Richieste Not Required	•	•
M061	Valvola di massima pressione VAF 06 - D Pressure relief valve VAF 06 - D	•	/

• Disponibile - Available

/ Non Disponibile - Not Available

Per le caratteristiche vedere il catalogo valvole
For the feature see catalogue valves

8A - CARATTERISTICA VALVOLA / VALVES FEATURE

		VALVOLE / VALVES	
		XXXX	M061
000	Caratteristica non necessaria Feature not necessary	•	/
001	Non Tarata (Campo Taratura 50÷150 bar) Not Set 50÷150 bar [725 to 2175 psi]	/	•

• Disponibile - Available

/ Non Disponibile - Not Available

Per la fornitura di valvole tarate contattare Uff. Tecnico.
Please contact Technical department for valve which require specific setting

9 - CARATTERISTICHE SPECIALI / SPECIAL FEATURE

XXX	Non Richiesta Not Required
TES	Tachimetro TAC-E (Senza sensore) - Senso di rotazione impiego SX (Standard) TAC-E Tachometer (Without sensor) - CCW suitable direction of rotation (Standard)
TED	Tachimetro TAC-E (Senza sensore) - Senso di rotazione impiego DX (Opzionale) TAC-E Tachometer (Without sensor) - CW suitable direction of rotation (Optional)

10 - OPZIONI / OPTIONS

XX	Non Richieste Not Required
01	Verniciato Nero RAL 9005 Black Painted RAL 9005

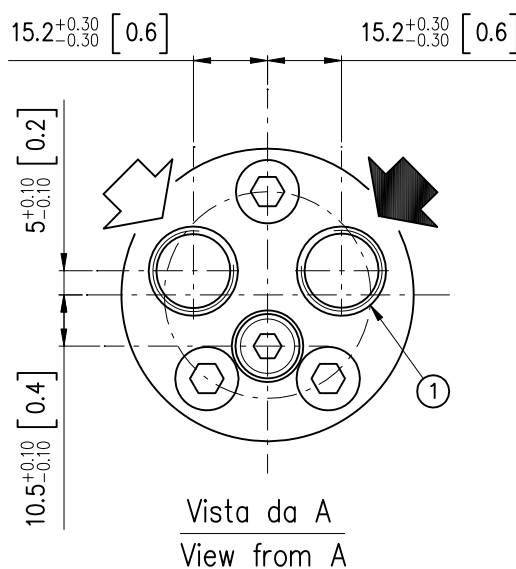
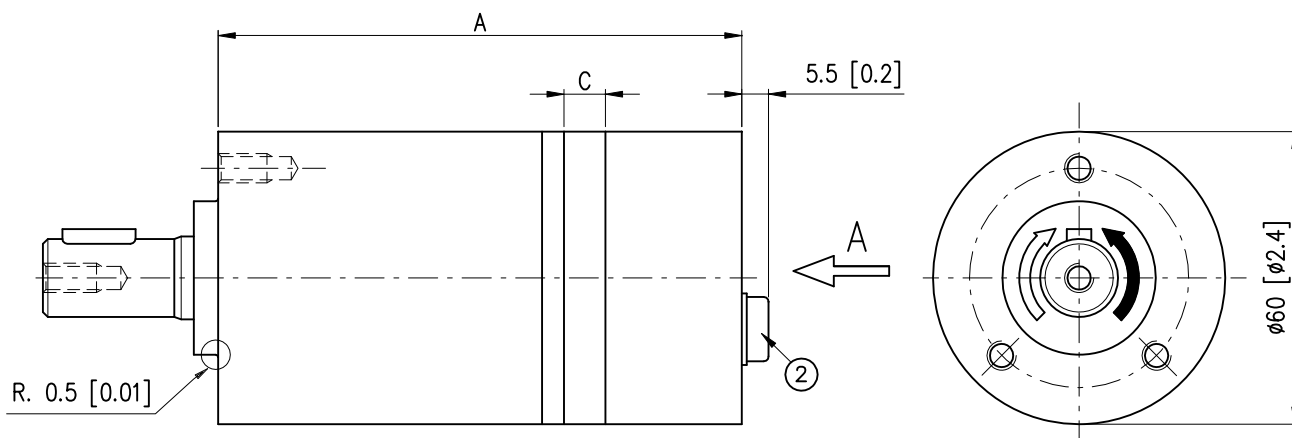

ATTACCHI M06 / M06 MAIN PORTS

ATTACCHI S06 / S06 MAIN PORTS

- 1) N.2 Fori di alimentazione 3/8 G (BSPP) prof. filetto 12mm
N.2 3/8 G (BSPP) main ports thread depth [0.46in]
- 2) Drenaggio motore 1/8 G (BSPP) prof. filetto 9mm
1/8 G (BSPP) drain port thread depth [0.35in]

- 1) N.2 Fori di alimentazione 9/16"-18 UNF prof. filetto 13mm
N.2 9/16"-18 UNF main ports thread depth [0.5in]
- 2) Drenaggio motore 7/16"-20 UNF prof. filetto 12mm
7/16"-20 UNF drain port thread depth [0.5in]

		BGM 013	BGM 020	BGM 032	BGM 040	BGM 050
A	mm [in]	104.5 [4.1]	107.5 [4.2]	112.5 [4.4]	116 [4.5]	120 [4.7]
B	mm [in]	-	-	-	-	-
C	mm [in]	5.5 [0.2]	8.5 [0.3]	13.5 [0.5]	17 [0.7]	21 [0.8]
Pesi - Weight	kg [lb]	2 [4.4]	2.06 [4.5]	2.15 [4.7]	2.2 [4.8]	2.25 [4.9]

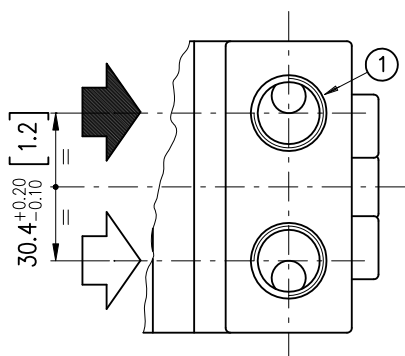
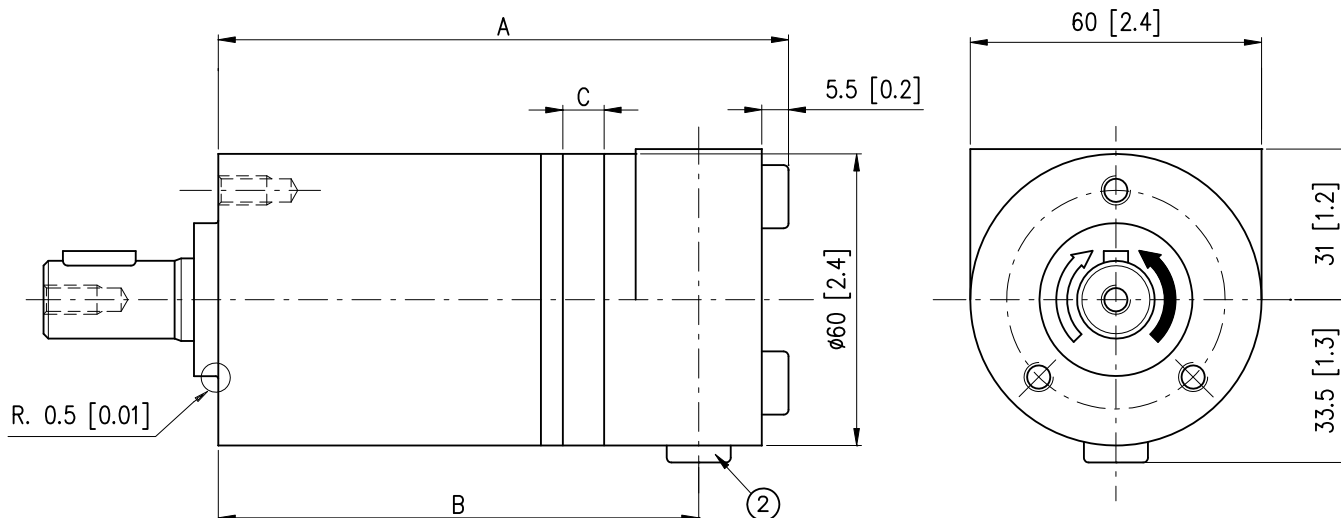

ATTACCHI M06 / M06 MAIN PORTS

- 1) N.2 Fori di alimentazione 3/8 G (BSPP) prof. filetto 12mm
N.2 3/8 G (BSPP) main ports thread depth [0.46in]
- 2) Drenaggio motore 1/8 G (BSPP) prof. filetto 10mm
1/8 G (BSPP) drain port thread depth [0.39in]

ATTACCHI S06 / S06 MAIN PORTS

- 1) N.2 Fori di alimentazione 9/16"-18 UNF prof. filetto 13mm
N.2 9/16"-18 UNF main ports thread depth [0.5in]
- 2) Drenaggio motore 7/16"-20 UNF prof. filetto 12mm
7/16"-20 UNF drain port thread depth [0.5in]

		BGM 013	BGM 020	BGM 032	BGM 040	BGM 050
A	mm [in]	113.8 [4.5]	116.8 [4.6]	121.8 [4.8]	125.3 [4.9]	129.3 [5.1]
B	mm [in]	95.3 [3.7]	98.3 [3.9]	103.3 [4.1]	106.8 [4.2]	110.8 [4.4]
C	mm [in]	5.5 [0.2]	8.5 [0.3]	13.5 [0.5]	17 [0.7]	21 [0.8]
Pesi - Weight	kg [lb]	2.1 [4.6]	2.16 [4.7]	2.25 [4.9]	2.3 [5]	2.35 [5.1]

Flangia S Flange

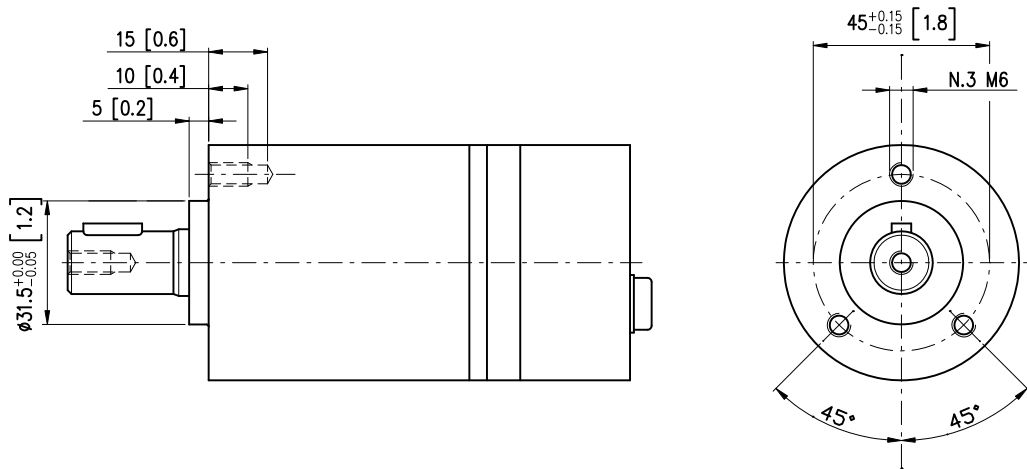

Flangia N Flange

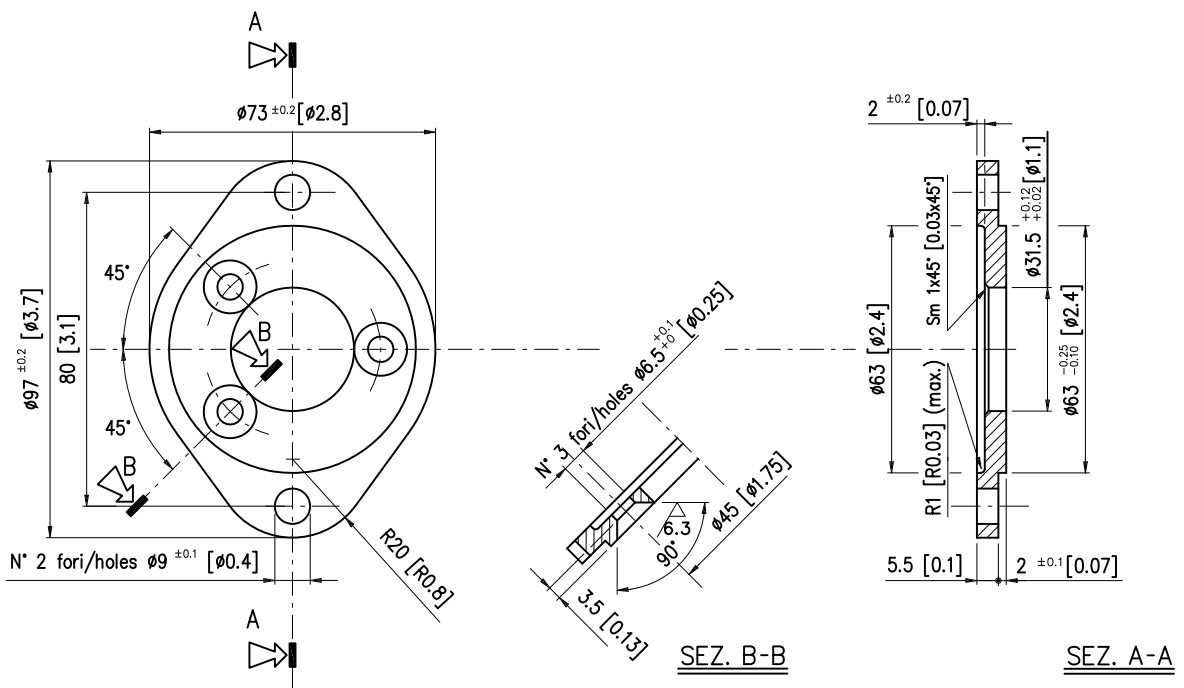

Montaggio flangia / Flange assembling

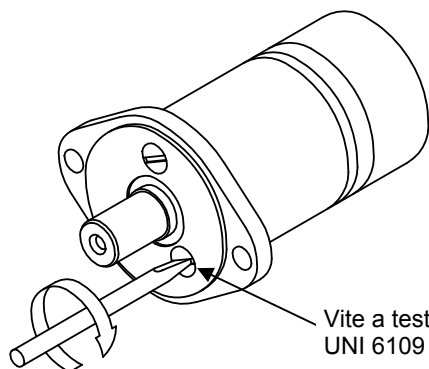

Vite a testa svasata piana con tagli UNI 6109 M6x14.
UNI 6109 M6x14 flathead screw.

ALBERO CILINDRICO CL160
CL160 CYLINDRICAL SHAFT

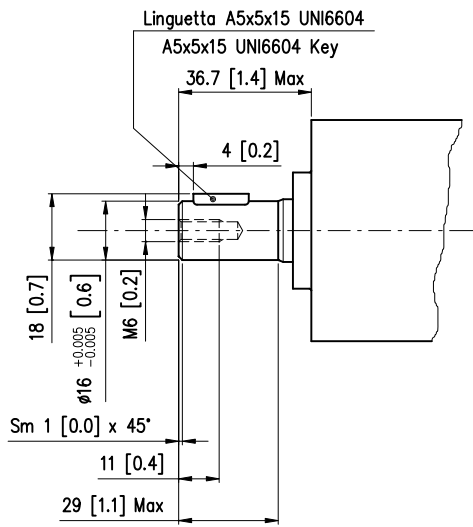

ALBERO SCANALATO SC160
SC160 SPLINED SHAFT

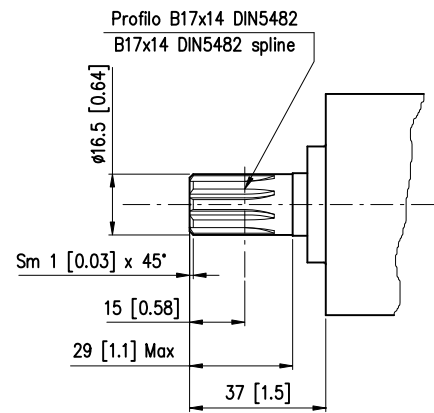

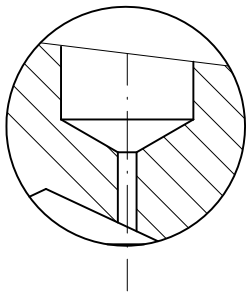
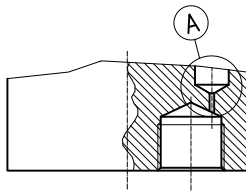

PART. A
Strozzatore fisso
Flow restrictor

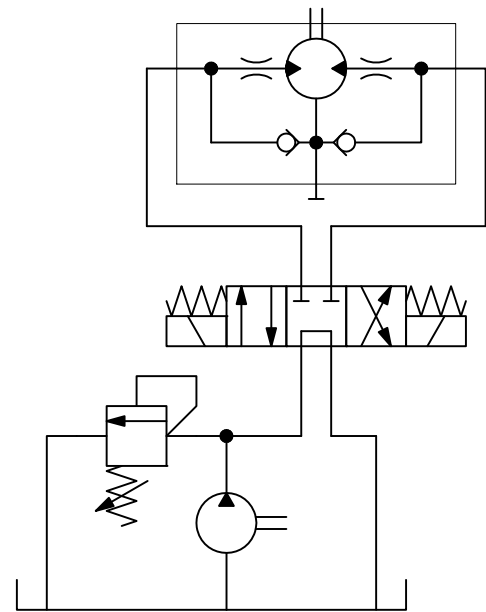

I motori BGM/FRQ dispongono di uno strozzatore sulla parte posteriore del motore che assicura velocità molto basse dell'albero anche in presenza di valori elevati di portata. Una tipica applicazione è quella della rotazione dei tubi di scarico delle turbine da neve montate su autocarri o trattori.

BGM/FRQ motors feature a restrictor at the back of the motor meant to ensure very low shaft speed though in presence of high flow. Typical applications are truck or tractor mounted snow blowers.

CURVE CARATTERISTICHE
PERFORMANCE CURVES

BGM...FRQ

Curva caratteristica della coppia (Nm) in funzione del numero di giri per le diverse pressioni di taratura della valvola a monte della strozzatura con foro D = 1.2 mm su motore BGM32.

Performance curves (torque/speed) according to pressure relief valve setting and 1.2 mm [0.04 in] diameter (for BGM32) of flow restrictor.

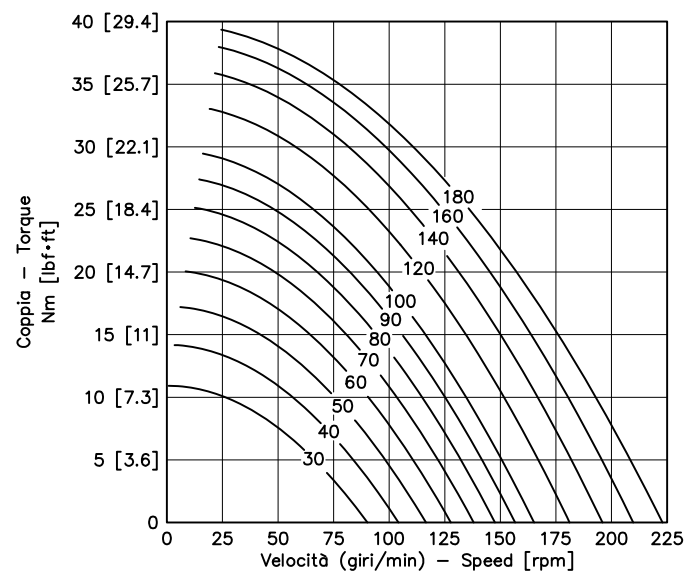

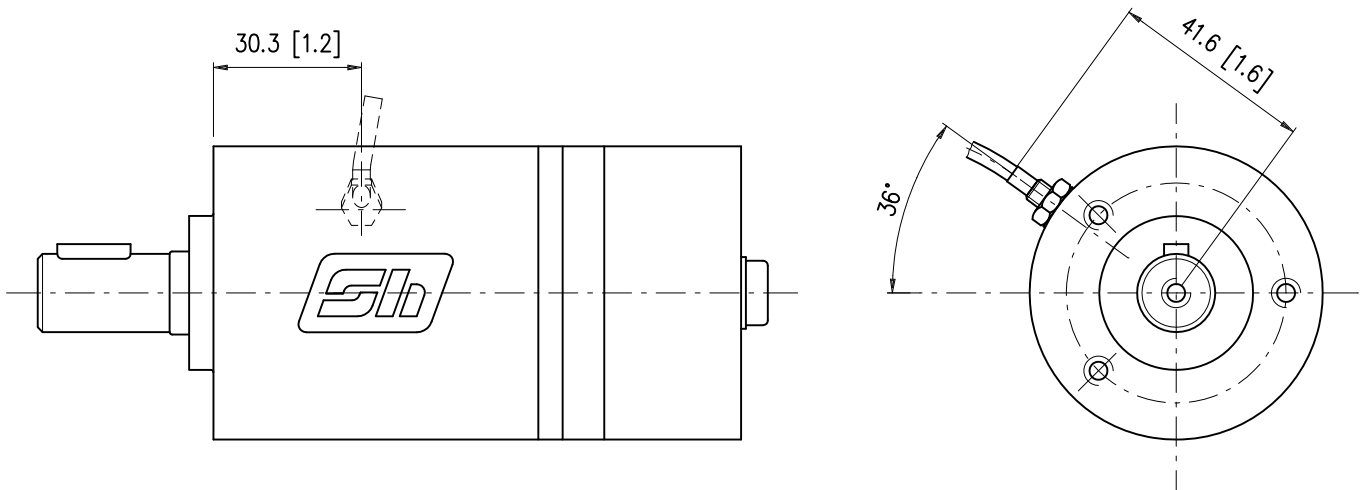

**SENSO DI ROTAZIONE OTTIMALE
SUITABLE DIRECTION OF ROTATION**

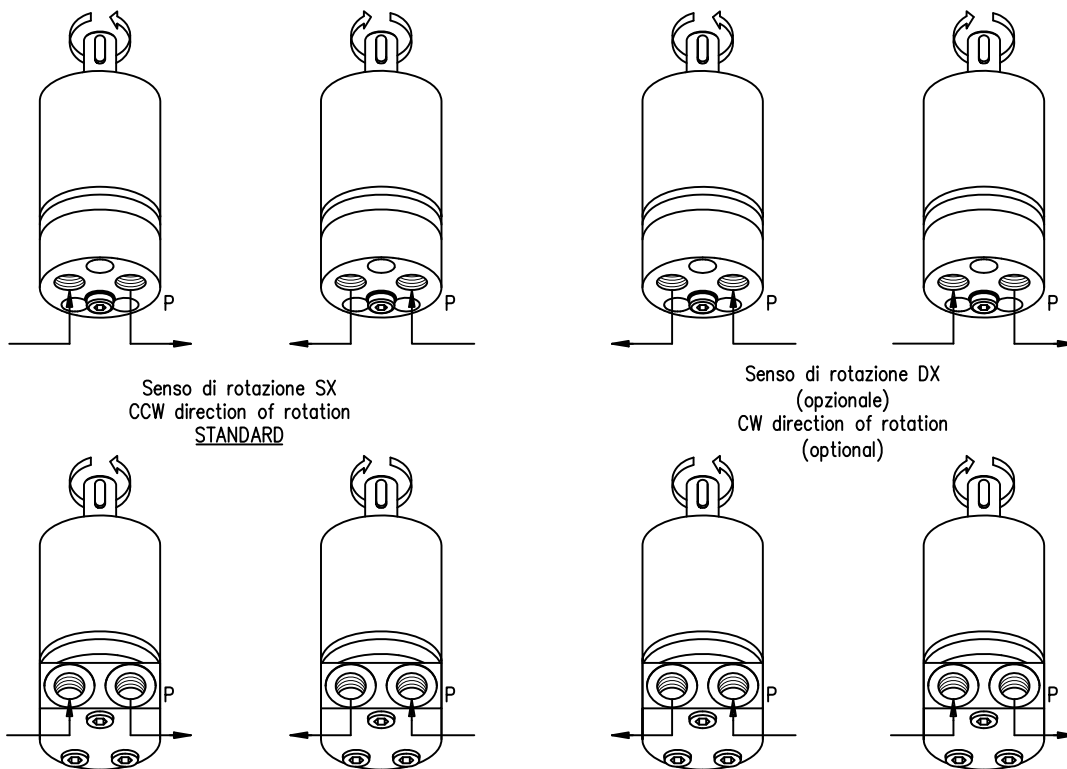

Caratteristiche sensore elettronico

Numero d'impulsi per giro = 4
Principio di funzionamento induttivo
Funzione di uscita PNP
Tensione nominale 10-30 V d.c.
Caricabilità massima 200 mA
Frequenza massima 3000 Hz
Campo di temperatura -25° C +85° C
Gradi di protezione IP 67
Lunghezza cavo 2 m

Segnale di uscita in versione elettronica
Output signal electronic tachometer

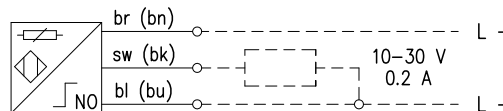
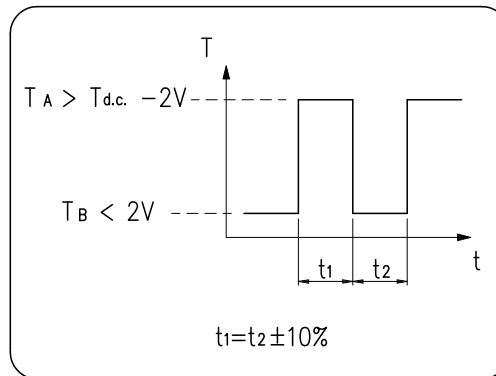

Electronic sensor technical features

Number of pulses for revolution = 4
Inductive principle
Output current PNP
Voltage 10-30 V d.c.
Max load 200 mA
Max frequency 3000 Hz
Temperature range -25°C +85°C
Enclosure IP 67
Cable length 2 m

**KIT DI TRASFORMAZIONE
TRANSFORMATION KIT**

...TAC-E

Kit di trasformazione SPO.0000.0121

1. Cod. 424.0090.0000
Sensore induttivo (1A) + dado di fissaggio M5x0.5 (1B)
2. Cod. 406.0730.0000
Rondella di tenuta GM2000 M5
3. Cod. 301.1780.0000
Corpo speciale per BGM versione TAC-E

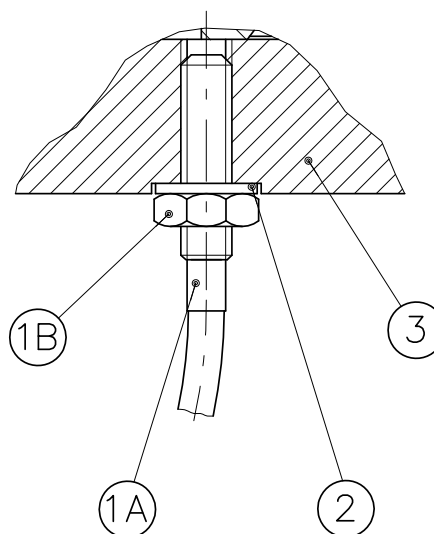

Transformation kit SPO.0000.0121

1. Cod. 424.0090.0000
inductive sensor (1A) + M5x0.5 locking nut (1B)
2. Cod. 406.0730.0000
Sealing washer GM2000 M5
3. Cod. 301.1780.0000
BGM TAC-E special version casing

CARICHI AMMESSI SULL'ALBERO SHAFT LOAD CAPACITY

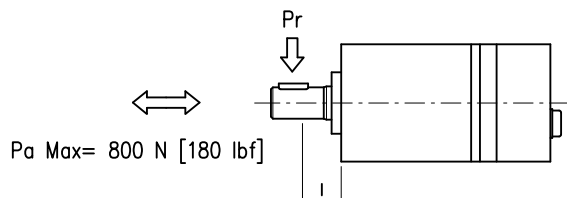
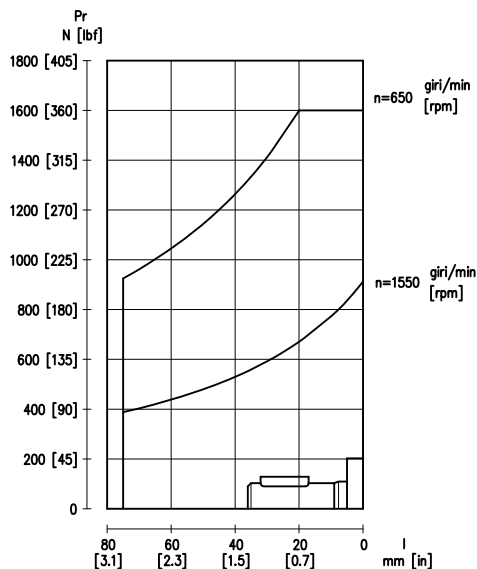

I motori della serie BGM, creati per avere minimi ingombri e alte velocità di rotazione, ammettono un carico radiale massimo sull'albero di 1600 N (Pr_{max}). Questo valore è stato calcolato con un numero di giri $n=650$ giri/min a una distanza dalla flangia $l=20$ mm.

Per il calcolo del carico radiale (Pr) ai vari numeri di giri (n) e alle varie distanze dalla flangia (l) si può utilizzare la formula che segue:

$$Pr = \frac{1500}{n} \cdot \frac{52300}{55.5 + L} \quad (\text{N})$$

La formula è valida per valori di $n \geq 650$ (giri/min) e $l \leq 75$ (mm). Se il numero di giri è minore del valore indicato (650) si deve utilizzare la curva o la formula considerando $n=650$ (giri/min).

Le curve rappresentate nel diagramma tengono conto della variabile " l " mantenendo costante n .

Compact design and high speed are the major features of the BGM line, together with a side load capacity of 1600 N [360 lbf] (Pr_{max}) at 20 mm [0.78 in] from flange; this figure applies to a 650 rpm speed. For other speeds and distances from flange the following formula applies:

This formula being valid for speed $n \geq 650$ rpm and $l \leq 75$ mm [2.9 in].

With $n < 650$ rpm refer to curve or formula considering $n=650$ rpm, in fact curves refer to $n=\text{const}$ with just " l " variable.

COPPIE DI SERRAGGIO TIGHTENING TORQUE

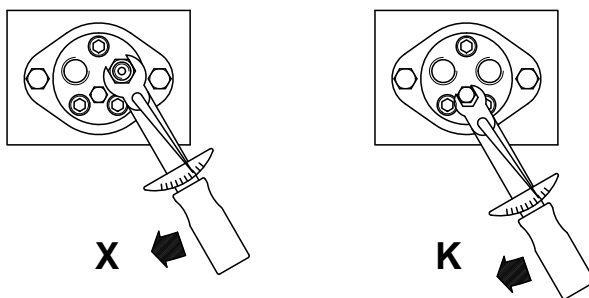

	X	K
Raccordi - Nipples	3/8 G (BSPP)	1/8 G (BSPP)
con rondella in acciaio - with steel washer	60 Nm 44.2 [lbf-ft]	20 Nm 14.7 [lbf-ft]
con rondella in alluminio - with aluminium washer	40 Nm 29.4 [lbf-ft]	10 Nm 7.3 [lbf-ft]
con rondella in rame - with copper washer	60 Nm 44.2 [lbf-ft]	20 Nm 14.7 [lbf-ft]

BGM 013

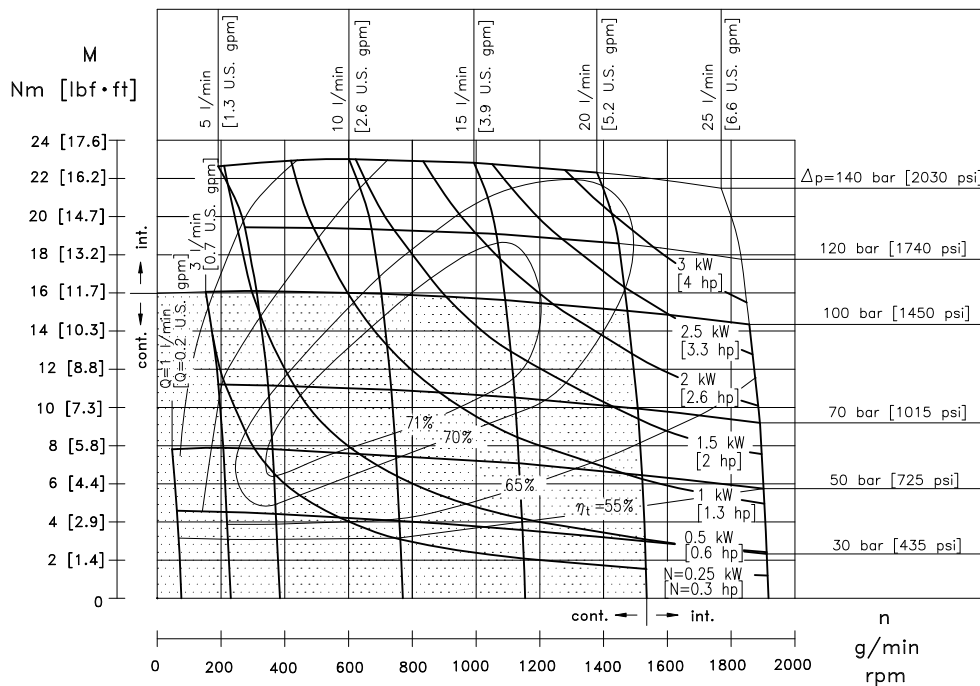

Pressioni e portate superiori a quelle ammesse in regime continuo non devono essere applicate contemporaneamente.

Exceeding continuous pressure values or exceeding flow values indicated, must not occur simultaneously.

BGM 020

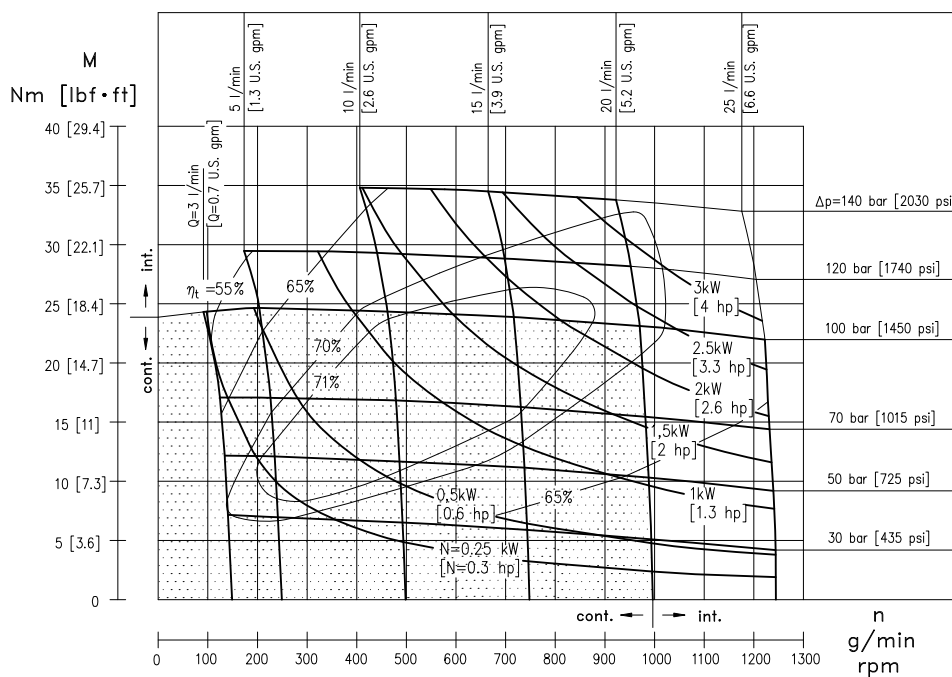

Pressioni e portate superiori a quelle ammesse in regime continuo non devono essere applicate contemporaneamente.

Exceeding continuous pressure values or exceeding flow values indicated, must not occur simultaneously.

BGM 032

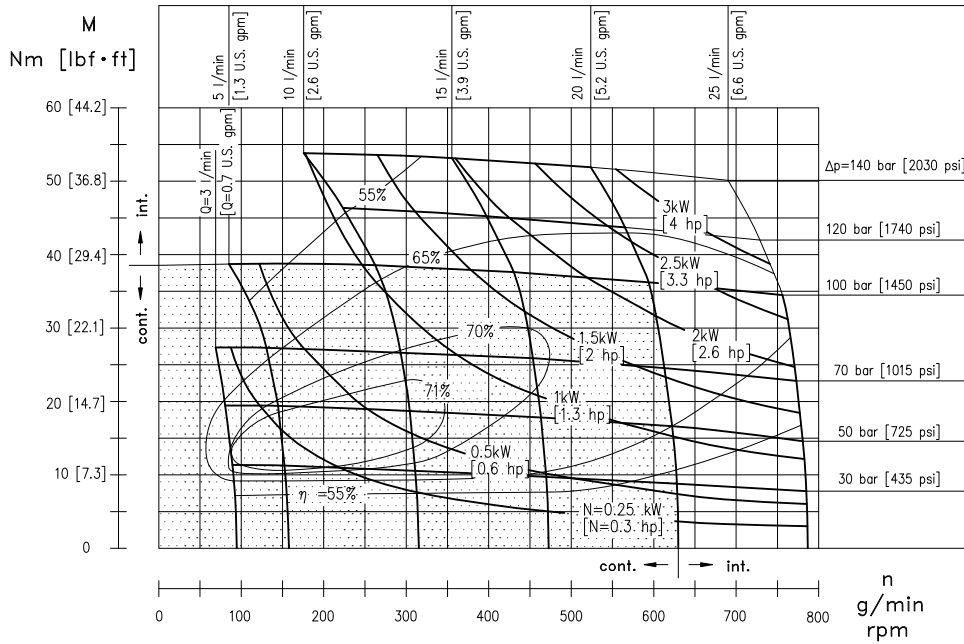

Pressioni e portate superiori a quelle ammesse in regime continuo non devono essere applicate contemporaneamente.
Exceeding continuous pressure values or exceeding flow values indicated, must not occur simultaneously.

BGM 040

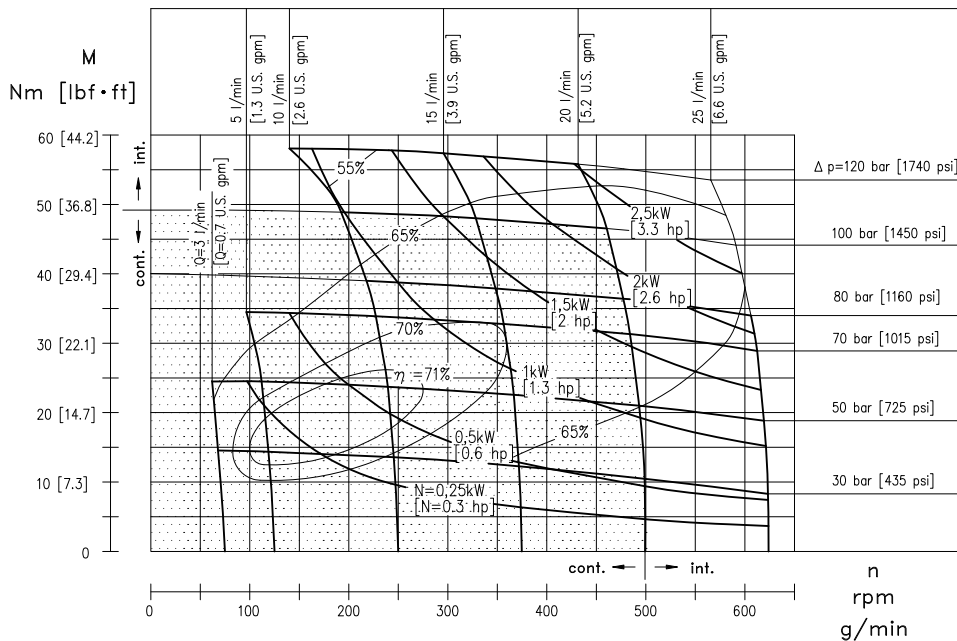

Pressioni e portate superiori a quelle ammesse in regime continuo non devono essere applicate contemporaneamente.
Exceeding continuous pressure values or exceeding flow values indicated, must not occur simultaneously.

BGM 050

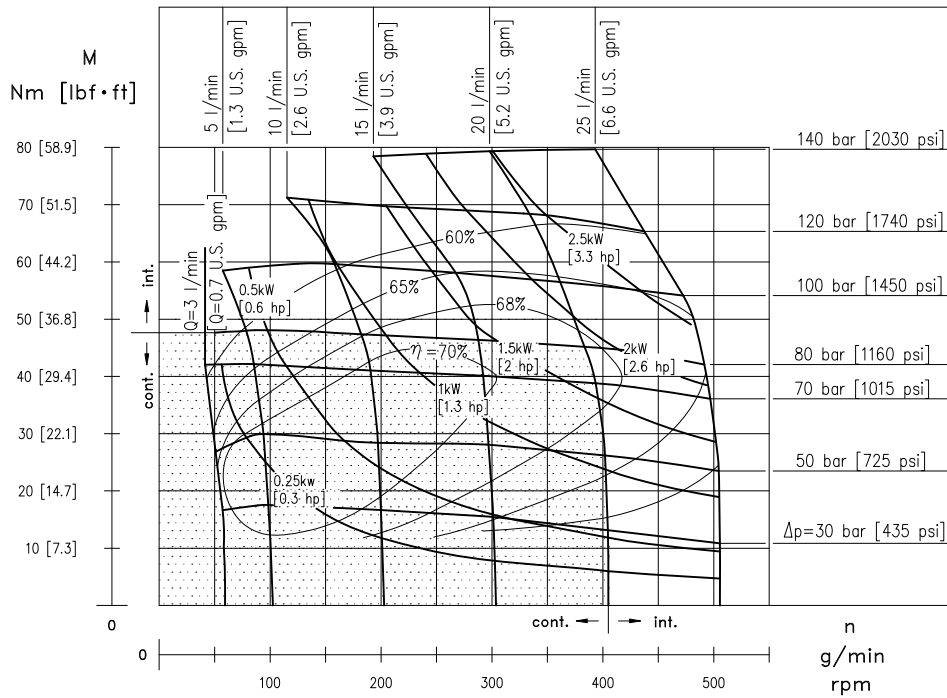

Pressioni e portate superiori a quelle ammesse in regime continuo non devono essere applicate contemporaneamente.
 Exceeding continuous pressure values or exceeding flow values indicated, must not occur simultaneously.



Informazioni sul prodotto

Dati i continui sviluppi, le modifiche e le migliorie al prodotto, la S.A.M. Hydraulik Spa non sarà responsabile per eventuali informazioni che possano indurre in errore, od erronee, riportate da cataloghi, istruzioni, disegni, dati tecnici e altri dati forniti dalla S.A.M. Hydraulik Spa. Non sarà possibile basare alcun procedimento legale su tale materiale.

Modifiche del prodotto. La S.A.M. Hydraulik Spa si riserva il diritto di variare i suoi prodotti, anche quelli già ordinati, senza notifica.

Notice

Due to the continuous product developments, modifications and improvements S.A.M. Hydraulik Spa will not be held responsible for any erroneous information or data that may lead to errors, indicated in catalogues, instructions, drawings, technical data and other data supplied by S.A.M. Hydraulik Spa. Therefore, legal actions cannot be based on such material. **Product development.** S.A.M. Hydraulik Spa reserves the right to make changes to its products, even for those already ordered, without notice.
